

Eliminating Waste with Internet of Things

Sony, Shweta ,Sonali P, Priyanka D.

Assistant professor Dept of Computer Science PDEA'S COEM
Student Dept of Computer Science PDEA'S COEM

Abstract - *The 21st century is the era of technological development. An estimation by Cisco says that more than 50 billion devices will be connected to the internet in the 21st Century. For the betterment of India internet of things play most important role. Devices are connected used for the purpose of safety and quality of life, city is surrounded by vehicle and infrastructure. System integrators, network operators and technology provide these are used in the working of government to give the smart solution. On standards-based communications platform it is difficult to generate the solution. Hence we proposed solution for a smart waste collection management based on providing , IoT prototype with sensors. This will make things to become "SMART" and influence the lives of humans. Data can be read ,collect and transmit large amount of data over the Internet .As the technological advancement increases in urbanization, industrialization and population governments across the global will need to device sustainable development plans. In recent years the and government are investing huge sums of money towards establishing smarter cities because notion of Smart City has been trending across the global . A Smart Waste Management System makes a smart city complete. In this project we are going to use the sensors and other components to make the smart dustbin which help to make clean and green India also help to reduce the diseases occur due to waste.*

Key words - IOT, NodeMCU, RTC, Ultrasonic Sensor, wi-fi, power supply, Load sensor, solar panel.

1. INTRODUCTION

In the areas like urban and rural as the population is increasing, this result in the increasing solid waste so that waste management become a global concern. In order to manage this overflowing garbage, we need to take right decision. Garbage generalization has main three type of sources viz. residential, commercial and industrial. In case of garbage present in restaurants, malls and other commercial establishment can be collected directly from the unit using vehicles. Industrial garbage in which waste produced in construction sites, various industries can also be disposed using different ways. Internet of Things (IOT) concept is being used for the effective handling of these waste like collection and disposal, which mainly deals with sensing, actuating, data gathering, storing and processing by connecting physical and virtual devices to the Internet. The change in the lifecycle of the people is one caused which make increase in the levels of waste generation. Serious challenges are occurred due to this. The waste

management schemes that are present, these are not enough to handle the ever- increasing levels of waste. Inefficient waste management techniques have given rise to the possibility of such kinds of problems. The system is inefficient as the cleaners are not aware of the garbage collected in the dustbins before reaching at the actual spot. Sometime it may happen that the garbage in the dustbin is full or sometimes it may be not up to the level where it needs to be emptied. Hence it reduces the efficiency of the system. To overcome this problem and to make the Waste management system efficient we have developed a Smart Dustbin concept. The smart dustbin uses a NodeMCU as the micro controller. An ultrasonic sensor is used in order to detect the level of garbage filled in the dustbin. An RTC module is used for registering time stamp. All this data is sent to an Android app which has an in built QR Scanner for ensuring Garbage Collection and Disposal.

2. PROPOSED METHODOLOGY

1. NODE MCU is main component used in this project which has multiple sensors also provide benefit to reduce the cost.
2. An Ultrasonic Sensor is used to determine the level of garbage in the dustbin It determine current status of the dustbin.
3. An RTC is used in order to keep a note of the time at which the dustbin was last cleared.
4. The device would be powered by USB charger as well as it can be operated using solar power.
5. The android app for the Smart Dustbin will have data such as garbage level, last cleared time and battery level of the device.
6. The android app will be developed on MIT App Inventor 2.

3. LITERATURE SURVEY

The literature surveyed some different papers to get information about the existing work which have been done Sauro Longhi, Davide Marzioni, Emanuele Alidor, Gianluca Di Bu`o, Mario Prist, Massimo Grisostomi and Matteo Pirro. Proposed, garbage collector supported by using sensor nodes which is providing information and status about the bin and also sending the retrieved data through DTN (Data Transfer Nodes). This bin has a custom prototype instead of basic installation of sensor nodes. A wireless sensor network is helped for controlling bin by gathering data from nodes. The limitation here is that the information about the bin is not directly transferred to the server or to the client; it needs to be sent through the Data Transfer Nodes. Shubham Thakkar, R. Narayanamoorthi, in this paper using the Near Infrared Reflectance (NIR) spectroscopy we can identify the type of plastic. The alienated dissipate

equipment from MSW (municipal solid waste) can be place in a needy area. By Using a dissenter material which can be mix into a uniform material. The entire process is repeated every hour. The fermentation mechanism took place in a sealed atmosphere, where bacteria converted into undividable enzymes which results in biogas Andrei Borozdukhin, Olga Dolinina and Vitaly Pechenkin, this proposed system consists of two parts: software and special signalling equipment. The equipment is placed on the side walls of the bin which consists of two parts: one is the receiver-transmitter and sensor. Sensor is used to indicate the level of the bin which is connected to the transmitter that transmits a signal of fullness of the bin to the receiver at the server host. A manager is appointed at the server side whose job is to find the shortest route and intimate it to the truck driver to

collect it in a short interval of time. Thompson A.F, Afolayan A.H, Ibidunmoye E.O Done work about the internet-based platform for the organization and monitoring of waste collection, discarding and carrying etc. This is comprised of the client, server and storage. The client is the device which can access the pages and forms used by web application e.g. PDAs, phones,

laptops etc. the desktop is a program that launches the application and makes it performs over the internet. In this, the back-end system is the web server and database management system that supervise the data used by the function to monitor the movement of data between user and system. The limitation of this paper is that it only shows the location of the bin in the web page.

AIMS AND OBJECTIVES:

- 1) Garbage level detection
- 2) Display Battery status in android app.
- 3) Display time stamp when garbage was lastly cleans.

4. RELATED WORK

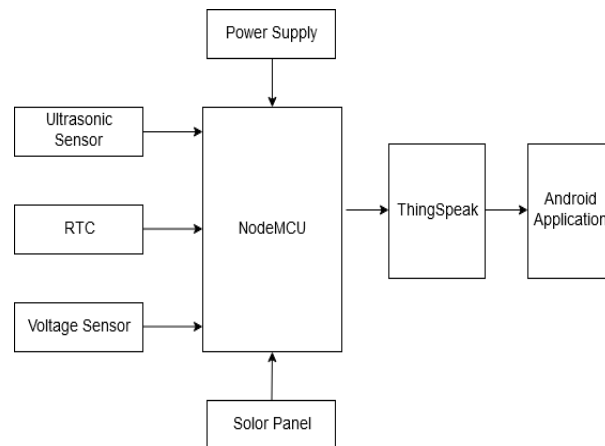

Fig 4.1 Architecture of smart dustbin

We propose a smart waste collection system on the basis of level of wastes present in the waste bins. The data obtained through sensors is transmitted over the Internet to a server for storage and processing mechanisms. It is used for monitoring the daily selection of waste bins, based on which the routes to pick several of the waste bins from different locations are decided. Every day, the workers receive the updated optimized routes in their navigational devices. The significant feature of this system is that it is designed to update from the previous experience

and decide not only on the daily waste level status but also the predict future state with respect to factors like traffic congestion in an area where the waste bins are placed, cost-efficiency balance, and other factors that is difficult for humans to observe and analyse. Based on this historical data the rate at which waste bins gets

Shows the system overview, whose components are briefed as follows

- **Ultrasonic Sensors:** We can determine the waste level by measuring the distance from the top of the trashing to the waste by sonar.
- **Real time clock (RTC):** RTC is used for updating time and dates. It displays the data on android application.
- **Voltage sensor:** voltage sensor used to determine, monitor and can measure the supply of voltage.

5. PROPOSED SYSTEM

According to the need of growing technology waste can be smartly manage hence we have propose the smart dustbin but it becomes expensive. We overcome this disadvantage by making the use of NODE MCU which have small size and there is no

filled is easily analysed. As a result, it can be predicted before the overflow of wastes occurs in the waste bins that are placed in a specific location. Depending on economic requirements specified at early stages, the optimized selection of waste bins to be collected is expected to improve collection efficiency

- **Solar panel:** A solar panel is design to absorb the sun rays as source of energy for generating electricity. In case if power supply don't work then solar panel is used.
- **NodeMCU:** It is open source iot platform. The term nodemcu by default refers to firmware rather than development kit.
- **Power supply:** It provides electricity supply.
- **Android App:** It provides current information of date and time related to cleaning of garbage.

need of external wifi connectivity this makes efficient application.

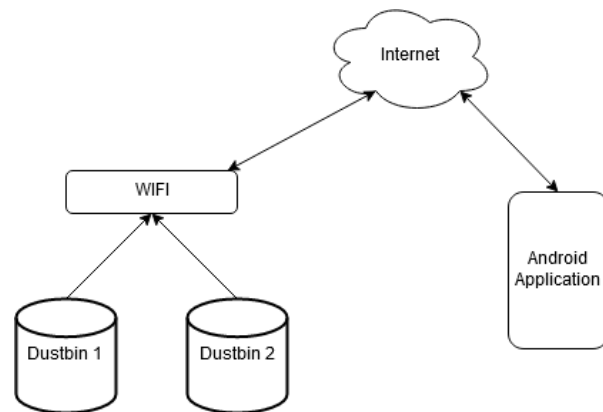

Fig 6.1 Working of the system

The above architecture shows working of the smart dustbin using sensors. In this architecture small device is placed on the dustbin. This device makes the dustbin to work smart. The main aim of the system is to monitor the garbage and make India clean. The device consist of different components such as solar, panel, ultrasonic sensor, power supply, RTC, nodeMCU etc. This device detect the current status and other information this detail information display on the android application. Through the internet device with sensor connected to android app shows the detail information such as current status of garbage ,time ,date, day of cleaning and also percentage

of garbage so that it shows in how many percentage the dustbin is clean. This system help to monitor reduce the efforts. The another feature we add scanning of the code when the worker make the dustbin empty and scan the code automatically the superior got the update that the garbage is picked up after the worker reaches the destination he will again scan the code and this will confirms that garbage is properly reach. Due to this monitoring is become too easy and work becomes more efficient and smart. In case if power supply is not done then we have used as backup i.e. solar panel .This will work as backup to system. It provides electric power supply to the device.

7. CONCLUSION

We have introduced an intelligent waste management system. The system architecture is completely IOT

8. CONCLUSION

We have introduced an intelligent waste management system based sensors. It is responsible for measuring the waste level in the waste bins and later send this data (through Internet) to a server for storage and processing. This data helps to compute the optimized collection routes for the workers. This paper shows technical way to manage the waste. Smart dustbins can be implemented by making the use of sensors. The accurate data from real time collected by the system. The smart dustbin prototype can be used in any conventional dustbin and make the Waste Management easier and efficient.

9. REFERENCES

- Arkady Zaslavsky, kostas Kolomvatsos, Alexey Medvedev, Pouria Amirian, Jeremy Morley, Stathes Hadjieftymiades "Challenges and opportunities of Waste Management in IOT-enabled Smart cities: A survey" an IEEE Transaction 2017.
- Krishna Nirde, Prashant S.Mulay, Uttam M.Chaskar" IOT based solid waste management system for smart cities" an ICICCS in 2017.
- Dr.N.Sathish Kumar, B.Vijayalakshmi, R.Jenifer Prathana, A.Shankar", IOT based smart garbage alert system using Arduino Uno" an IEEE in 2016.
- Andrei Borozdukhin, Olga Dolinina and VitalyPechkin, " Approach to the garbage collection in the Smart clean city Project", in Yuri Gagarin State Technical University of Saratov,Russia in 2016.
- Kanchan Mahajan, Prof.J.S.Chitode," Waste bin monitoring system using integrated technologies" an IRJET in july 2014.
- Prof.R.M.Sahu, Akshay Godase, Pramode shinde, Reshma Shinde," Garbage and street light monitoring system using IOT" an IRJET in April 2016.
- BelaalChowdhury,Morshed Chowdhury,"RFID based Real-time Smart waste management system", an Australasian telecommunication networks and application conference in 2017.