

Comparative Design Analysis of Straight Vertical Axis

Parveez, Patel
Department Of Mechanical Engineering
School Of Engineering & IT, MATS University, Raipur

Abstract:- Fossil fuels are depleting at very fast rate and will have shortages in near future. Also prices of fuels increases day by day, demands for renewable energy sources increases for electrical power generation. Wind energy is available in nature in free of cost and in abundant form is excellent option for generation of electric power through wind turbine technology. Wind turbine is machine used to convert kinetic energy of wind to electrical energy. Wind turbines are the solutions for the today's energy crisis within the world. In India plays a major role in renewable energy generation because it covers over seventieth of the energy generated by the renewable energy sources. Still we've turbine with but thirty ninth percent efficiency. For improvement in performance of turbine we want to develop some technique for performance prediction of the turbine. the event of performance prediction is one among the foremost vital aspects of the planning of wind turbines. a longtime methodology is employed to calculate the optimum performance parameters of the horizontal axis turbine in provisions of the foremost important parameters like tip speed magnitude relation, blade variety, pitch angle and wind speed. This paper presents aerodynamic modeling, performance evaluation of vertical axis wind turbine (VAWT). Aerodynamic modeling of VAWT is designed using software tools by considering NACA0012 airfoil whose chord length is 0.12 m.

Keywords:- Airfoil, NACA0012, Straight Blade

I. Introduction:-

Life is nothing but a continuous process of energy conversion and transformation. The accomplishments of civilization have largely been achieved through the increasingly efficient and extensive

harnessing of various forms of energy to extend human capabilities and ingenuity. Energy is similarly indispensable for continued human development and economic growth. Providing adequate, affordable energy is essential for eradicating

poverty, improving human welfare, and raising living standards world-wide. And it will be difficult to address environmental challenges, especially those associated with poverty. Wind energy converters harness the kinetic energy contained in flowing air masses. In the following, the fundamental physical principles of this type of energy conversion are explained. Most modern wind energy converters are equipped with rotors to extract wind power, and consist of one or several rotor blades. The extracted wind power generates rotation and is thereby converted into mechanical power at the rotor shaft. Mechanical power is taken up at the shaft in the form of a moment at a certain rotation and is transferred to a machine (such as a standstill; air would fail to enter the swept rotor area, and wind power would no longer be available. There are two different physical principles to

with- out economic growth,

extract power from wind. The airfoil drag method is based on the wind drag force incident on a wind-blown surface. The second principle, also referred to as aerodynamic or airfoil lift principle, which is based on flow deviation inside the rotor is at present predominantly applied for wind energy conversion. The implementation of an innovative aerodynamic control technique in wind turbines is a point under extensive investigation since the conventional wind turbine blade technology is reaching its limits. The main effort of the wind turbine industry in the field of aerodynamics related to the development of blades which offer better performance, increased reliability and faster control of larger wind turbines.

II. Purpose of the present work

A lot of activities have been considerably increased in many countries recently in the field of renewable energy conversion due to the worldwide energy crisis. Although considerable progress in wind energy has already been achieved, the present technical design relying exclusively on horizontal axis turbines is not yet adequate to develop reliable wind energy converters, particularly for conditions corresponding to low wind

speeds and/or urban areas. Vertical Axis Wind Turbines (VAWT) like the Darrieus turbine appear to be particularly promising for such conditions, but suffer from a low efficiency compared to horizontal axis turbines.

Additionally, VAWT are not always self-starting, which is a major drawback. As a whole, the main disadvantages are:-

- A low efficiency.
- Difficulties by self-starting.

Resonance issues and material fatigue due to oscillating power output,

- not allow controlling the orientation of the rotor blades.
- VAWT also produces a much larger shaft bending moment than a HAWT. Due to substantially larger bearing and shaft loads, there is increased possibility of shbearing

Additionally, recent studies show that vertical- axis turbines can be installed much closer to each other compared to horizontal-axis turbines, so that the power density per square meter could be at the end considerably higher than for the configurations used presently. Citing directly Prof. J. Dabiri from Caltech in the journal of Mechanical Engineering (March 2011, p. 12): "Vertical-axis turbines spaced four diameters apart had power densities between 10 and 15 times as great as standard wind farms. These results could lead to a reassessment of vertical- axis turbines which could revolutionize the wind power sector". As an alternative derived from the standard configuration, Straight Darrieus wind turbines (called also in what follows H- rotors, Fig.1) have even more attractive characteristics.

III. Design of Vertical Axis Wind Turbine

Design of VAWT is described below in three stages-first is selecting the suitable airfoil, second is modelling of the airfoil and other components in software tools like solid

i) **Airfoil Selection** :-In this design, NACA 0012 airfoil is selected see in Fig. 1. (a) The selected airfoil is symmetrical and the four digits of any NACA series airfoil defines the wing profile by the following:

fracture and failure.

On the other hand, some of the major advantages of VAWT are:-

- A greater compactness.
- A simpler design, leading to relatively low costs;
- The possibility of housing sensitive mechanical and electrical components, gearbox and generator at ground level.
- The absence of any yaw-control system.

Instead of curved rotor blades, straight blades are used, directly connected to the rotor shaft by struts. The H-rotor is also able to accept wind from any direction; it is very easy to build, install and maintain, leading to extremely low costs. However, a quantitative prediction of its aerodynamic performance is still very complicated, in particular due to the occurrence of dynamic stall on the blades. As a consequence, and even if many interesting works have already been published on this configuration, as discussed later, a thorough optimization of this design has not been completed yet. The central drawback of a Darrieus turbine is its low efficiency like all VAWTs, especially at low speed ratio ($1/4 uR/U$). Therefore, many authors have already tried to identify the best principles of operation ..

works, and third is fabricating the model by selecting appropriate material.

- Maximum camber as percentage of chord is described by the first digit.
- The distance of maximum camber from the airfoil leading edge in

terms of percent of the chord is

- described by the second digit.
- Maximum thickness of the airfoil as percent of the chord is described by the last two digits.
- From the above three points, the selected airfoil profile is described that it has no camber and it has 12 % thickness to its chord length ratio.

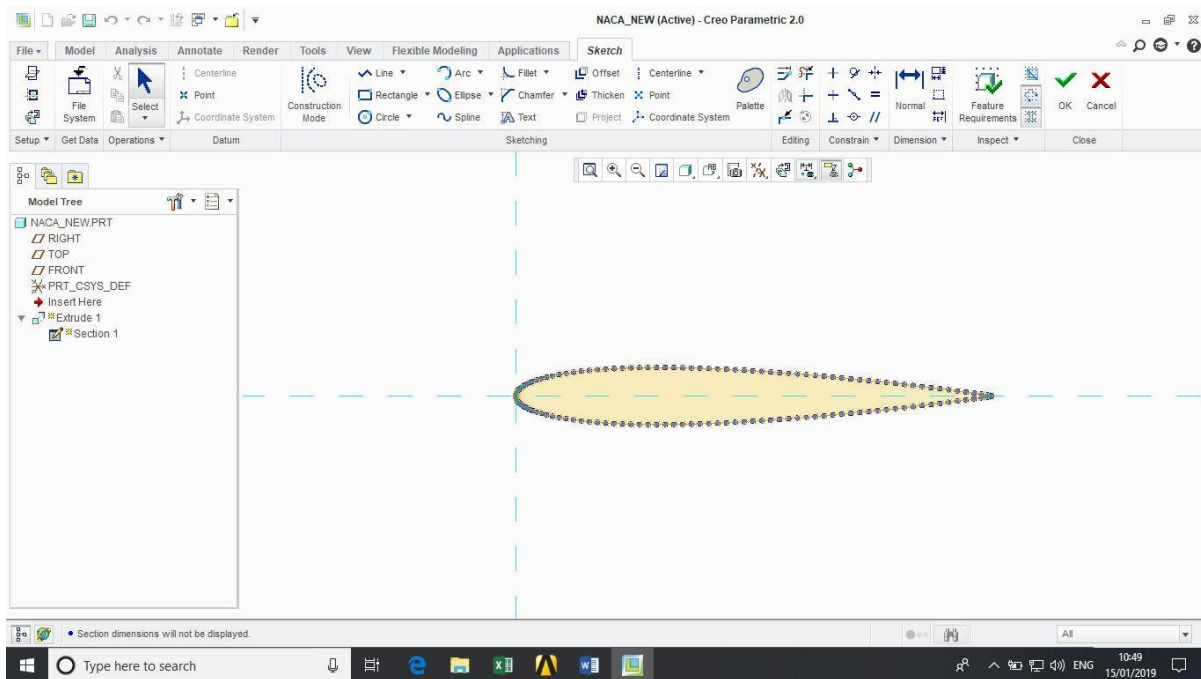

Figure No 1:- Selection of Airfoil NACA0012

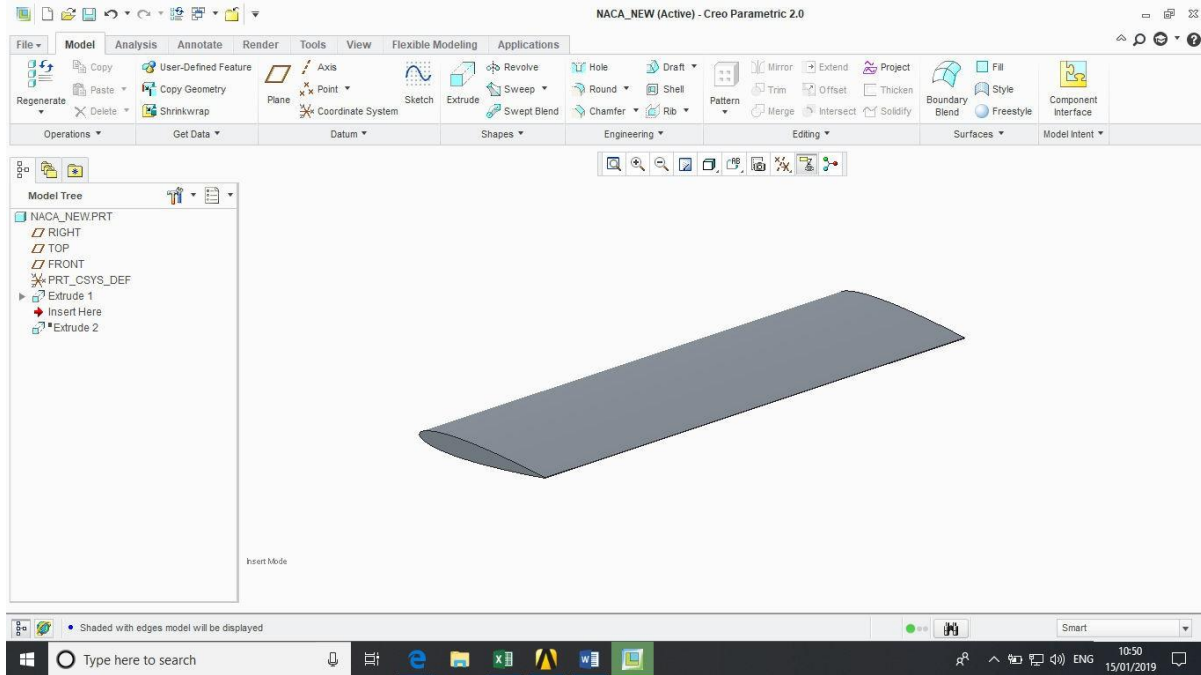

Figure No 2:- Exported Design of NACA0012 in Creo

IV. Modeling of VAWT :-

After selecting the airfoil, its co-ordinates were exported into Creo software for designing the airfoil structure and to design further as per the dimension required, see in Fig. . The major components that are designed in this work for VAWT are airfoil shaped blades, rotor center shaft, bearing, bottom bearing holder and rotor support frames. All these components were designed individually and later assembled together to make an aerodynamic model of VAWT. Here straight blades are used in modeling VAWT whose radius is almost equal over its length, this is responsible for power generation over its complete length.

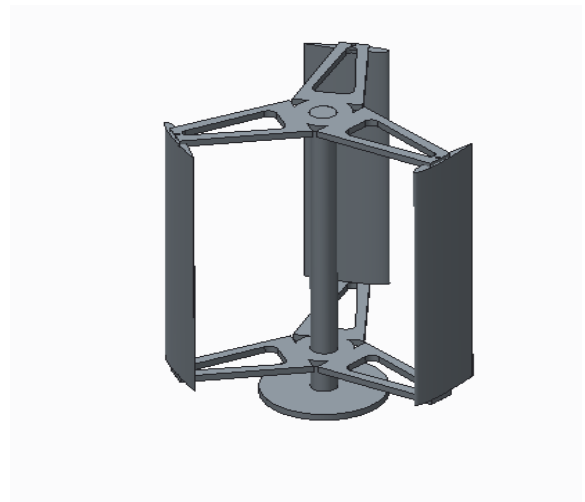

Figure 3:- HEIGHT 400MM ANGLE 0 DEGREE



Figure 4:- HEIGHT 600MM ANGLE 0 DEGREE

Figure 5:- HEIGHT 800MM ANGLE 0 DEGREE



V. MODELING AND SIMULATION:-

Using the modelling software Creo and design module in ANSYS, the profile of the NACA0012 aerofoils for VAWT design were drawn into two dimensional and three dimensional model for the straight blade Darrieus type of rotor.

VI. Construction of geometry model :-

The mesh and boundary conditions are shown in Figure 8 & 9 in which the interior domain containing the wind turbine blades was considered as the moving mesh, while the outer domain was stationary.

i) PREPROCESSING

Creo is the software for creating the 3-D model and Ansys 18.1 is generating the mesh. This is used as the pre-processor to run the simulation in

Fluent. All the specifications used here are based on the manufacturer data provided for this particular type of turbine.

ii) FLUENT PROCEDURE

Fluent is the commercial software used frequently by engineers for modeling heat transfer and fluid flow characteristics in complex geometries. In this project, Fluent is used to analyze the fluid flow properties such as distribution and separation of the velocity through and around turbine blade, and variables to describe the fluid flow.

iii) GEOMETRY AND MESH GENERATION

3D modeling of the turbine and generation of mesh is the main challenge for conducting the numerical simulation. In this particular case the different height of blade and lift based design are analyzed

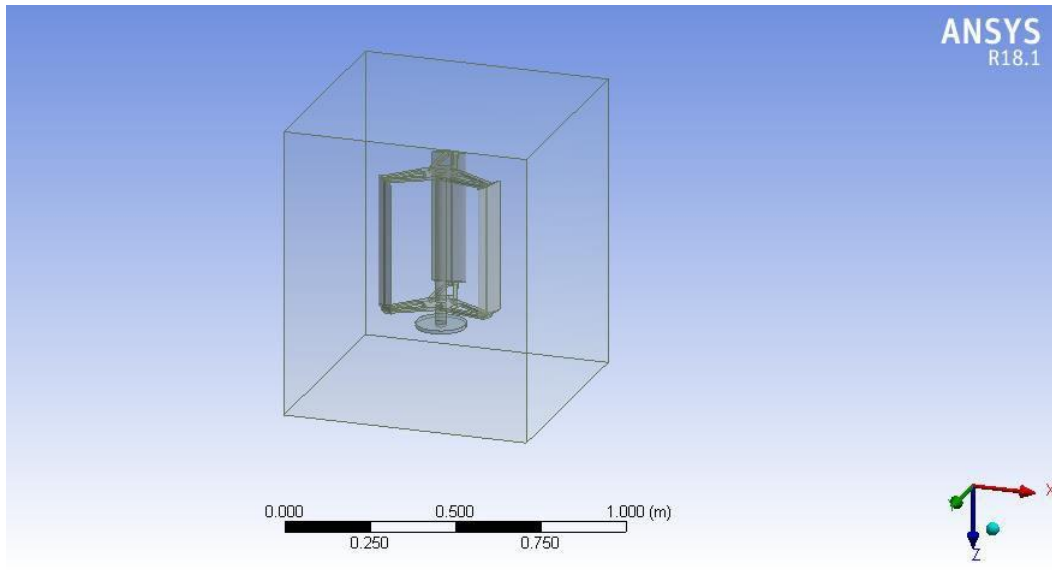

Figure 7 :- Geometry With Enclosure

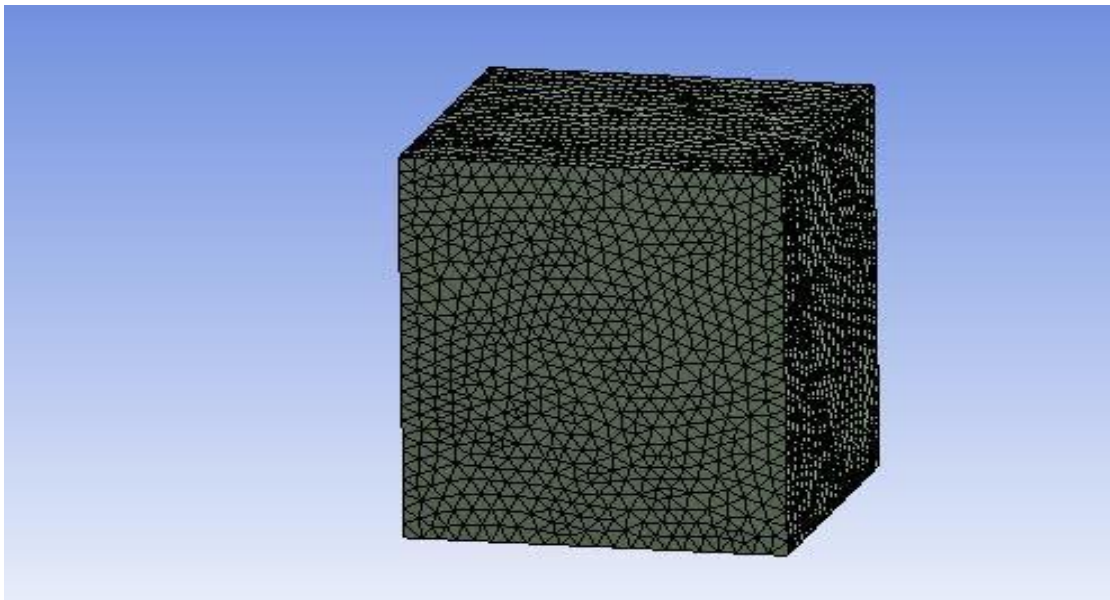

Figure 8 :- Meshing of Straight Blade with Enclosure

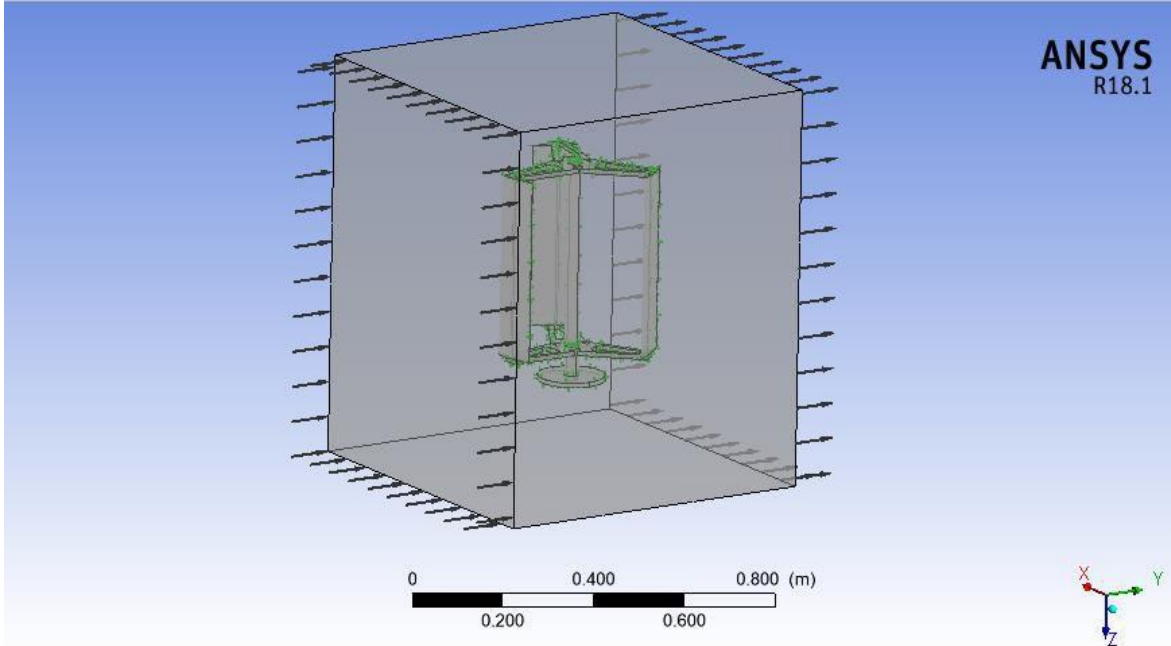

Figure 9:- Loads And Boundary Condition

Results:-

Results For Height 400mm at Velocity 10 m/s

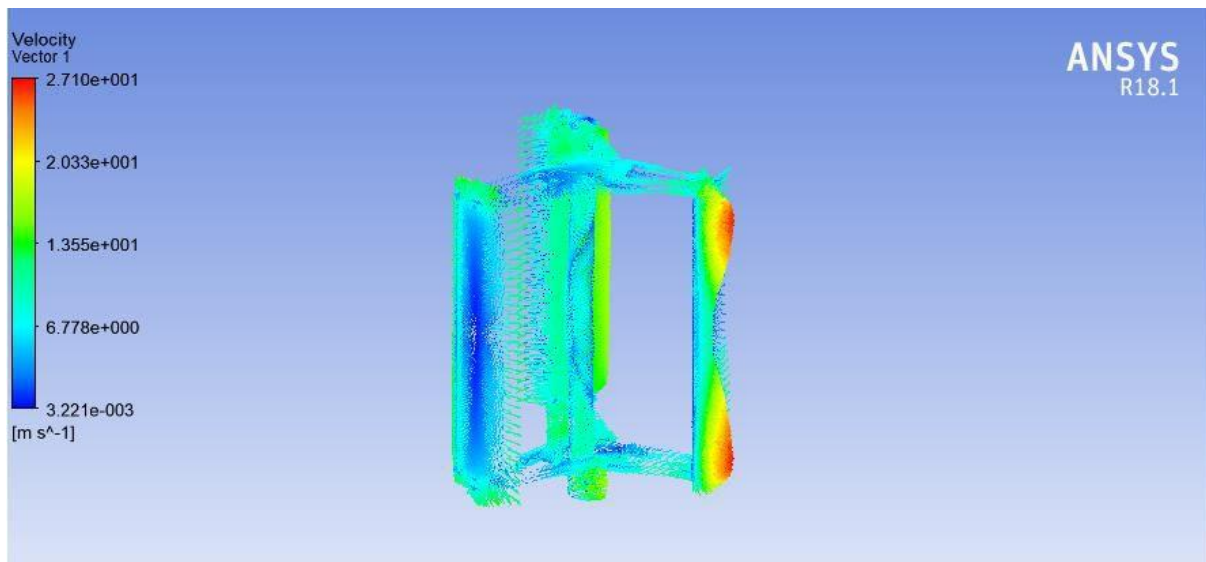

Figure10 :- Velocity Vector at 10 m/s

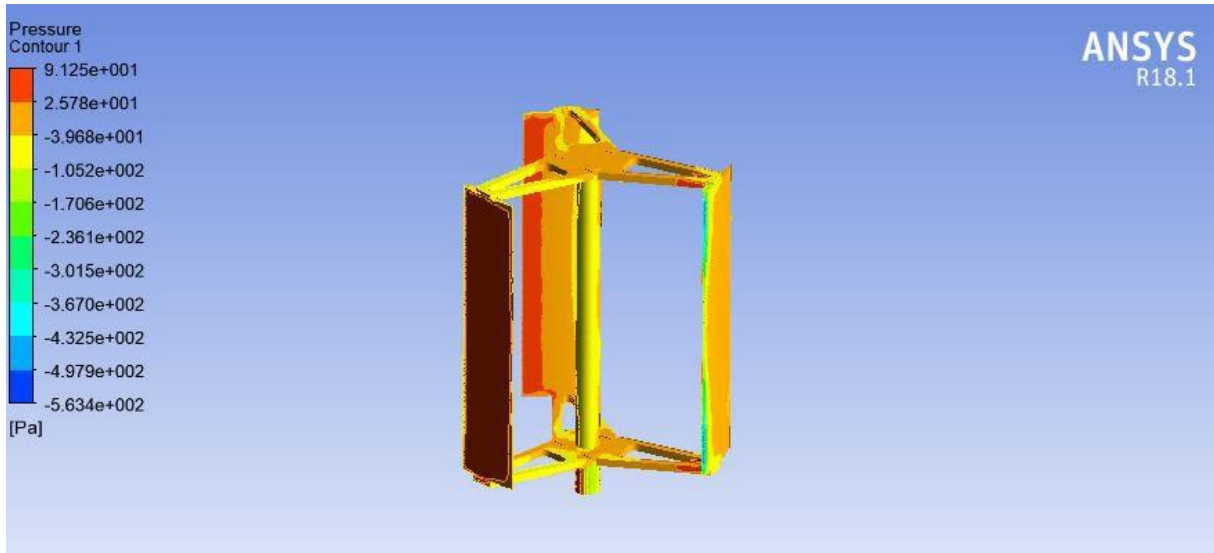

Figure 11:- Pressure Contours

Results For Height 400mm at Velocity 5m/s

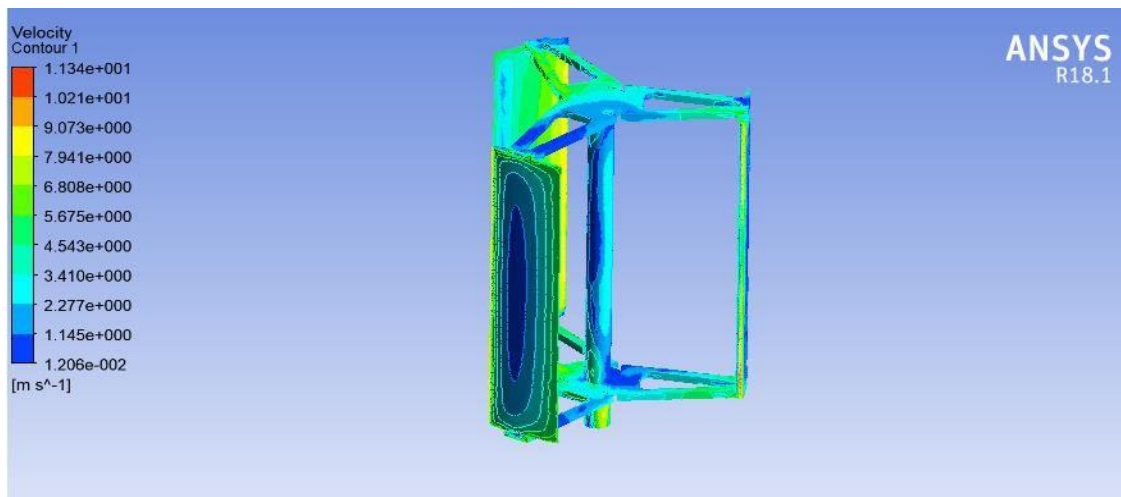

Figure 12:- Velocity at 5m/s

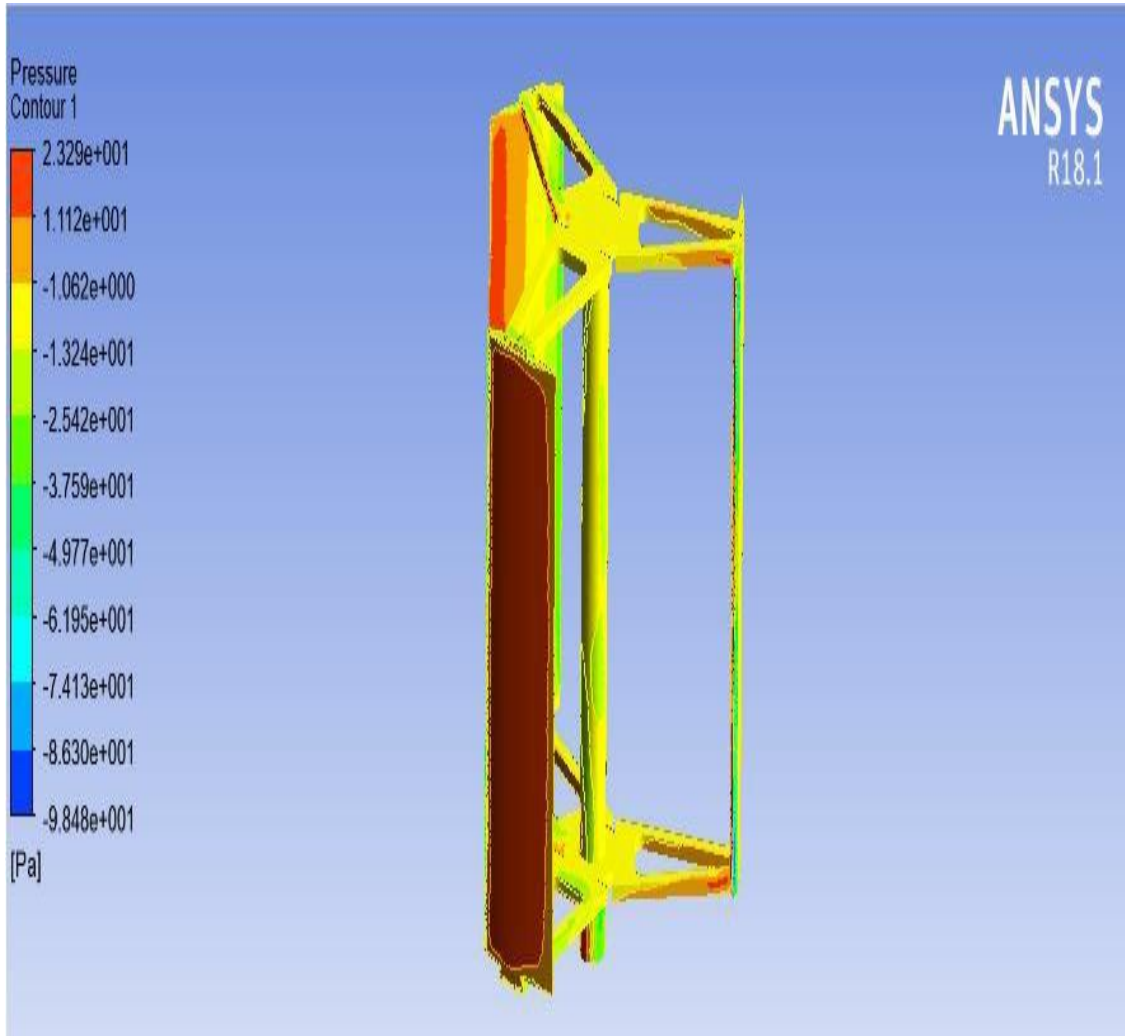

Figure 13:- Pressure Contours

Conclusion:-

In this paper, the design and analysis of straight blade wind turbine with the aim providing electricity in remote areas operation was proposed. Considering the availability of low speed wind. To this end, simulations were performed using Creo and ANSYS Fluent and software to increase the results accuracy the maximum and mean velocity was 10 m/s and 5.6 m/s, respectively. Using the simulation results, the best performance of blades

for straight blade vertical axis wind turbine turbine was related to the NACA 0012. Finally, the obtained results were shown the good accuracy. However future work should be done on selecting a high quality and lighter weight material for designing. This would help in achieving good cut in speeds. Apart from this the performance of the wind turbine can be evaluated by modelling and testing with different type of airfoils.

References:

- M.H. Mohamed, A.M. Ali, A.A. Hafiz , CFD analysis for H-rotor Darrieus turbine as a low speed wind energy converter , Mechanical Power Engineering Dept., Faculty of Engineering e Mattaria, Helwan University, P.O. 11718, Cairo, Egypt (2014) 2. Dr.P.M.Ghanegaonkar , Ramesh K.Kawade , Sharad Garg, Conceptual Model of Vertical Axis Wind Turbine, International Journal of Innovative Research in Advanced Engineering (IJIRAE) Volume 1 Issue 3 SPECIAL ISSUE (May 2014) 3. Mazharul Islam_ , David S.-K. Ting, Amir Fartaj, Aerodynamic models for Darrieus-type straight-bladed vertical axis wind turbines, Department of Mechanical, Automotive and Materials Engineering, University of Windsor, Windsor, Ont., Canada N9B 3P4 (2015).